

Using Your Setup Instructions

The Aero Setup Instructions are created specifically for your configuration. The instructions include an exploded view of the frame which is sequentially labeled. We encourage you to review the instructions before attempting to assemble your exhibit.

Connections are kept very simple; no tools required. Everything assembles with push-button connectors.

Cleaning and Packing Your Display

- 1) Use care when cleaning aluminum extrusion or acrylic inserts. Use only non-abrasive cleaners.
- 2) Retain all packing material. It will make re-packing much easier and will reduce the likelihood of shipping damage.

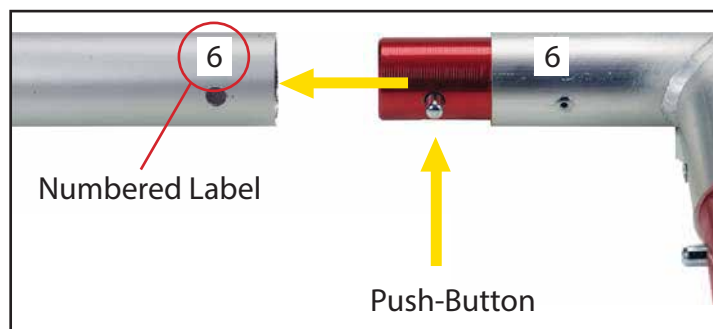

Connections are made by holding the button down and sliding the red tube into opposing tube until button locks into the hole. To disassemble, push button and pull or twist extrusions apart.

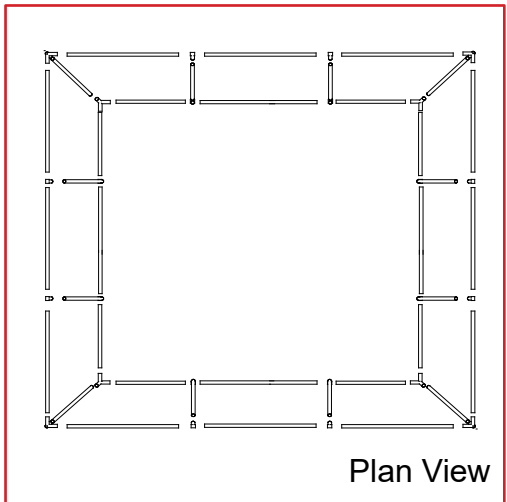
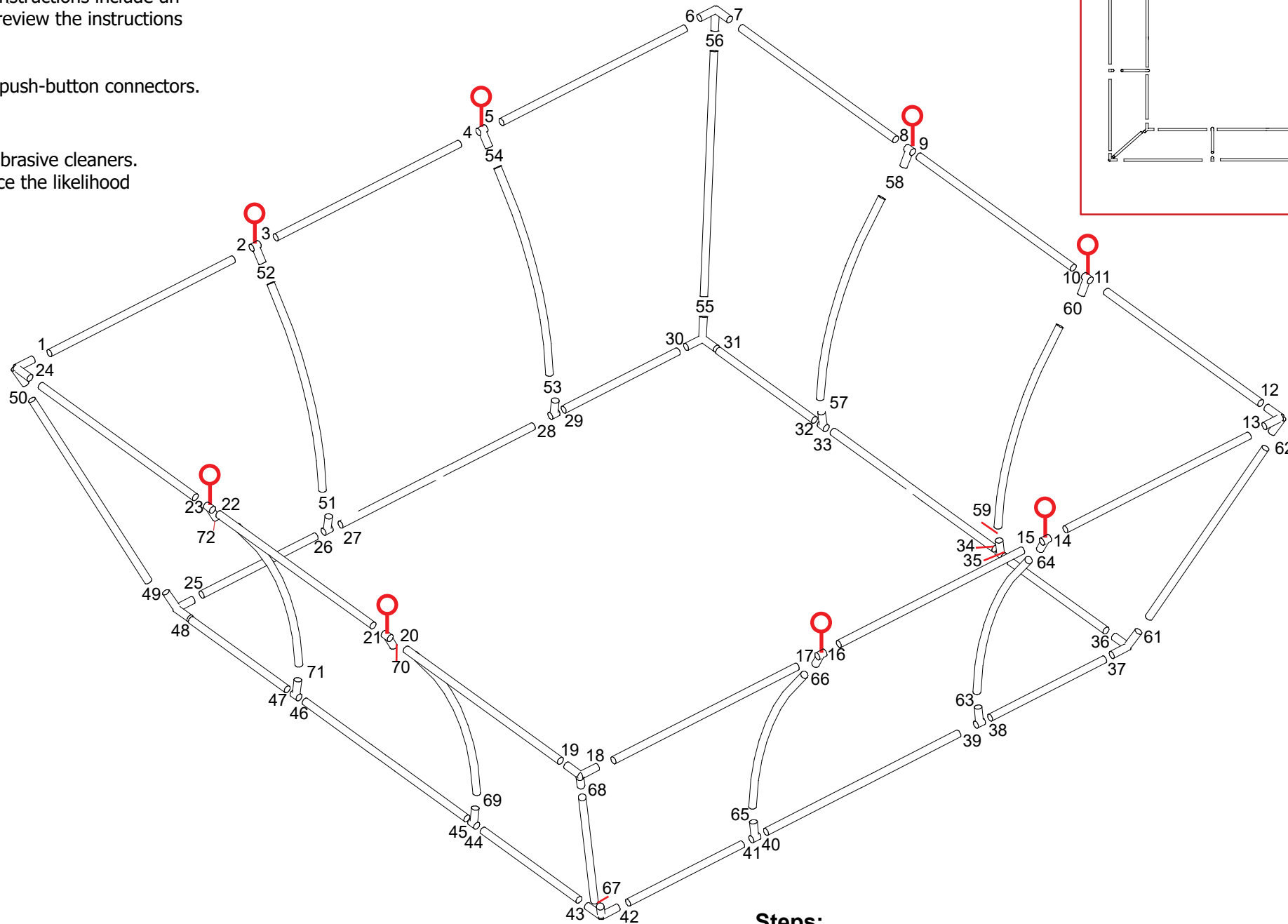
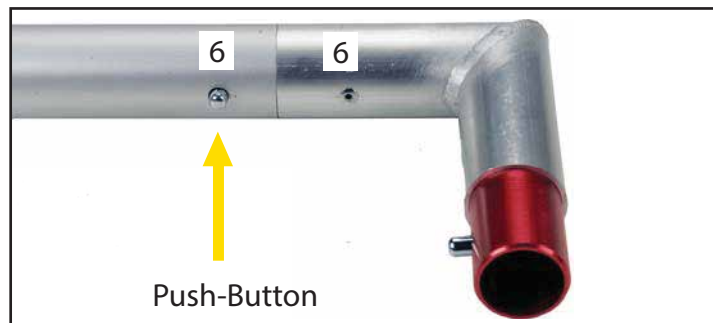

- Steps:**
- 1) Connect all upper and lower pieces together in numerical order.
 - 2) Connect lower section and upper section together using the 4 Straight Vertical supports and 8 Curved Vertical supports.

SETUP INSTRUCTIONS

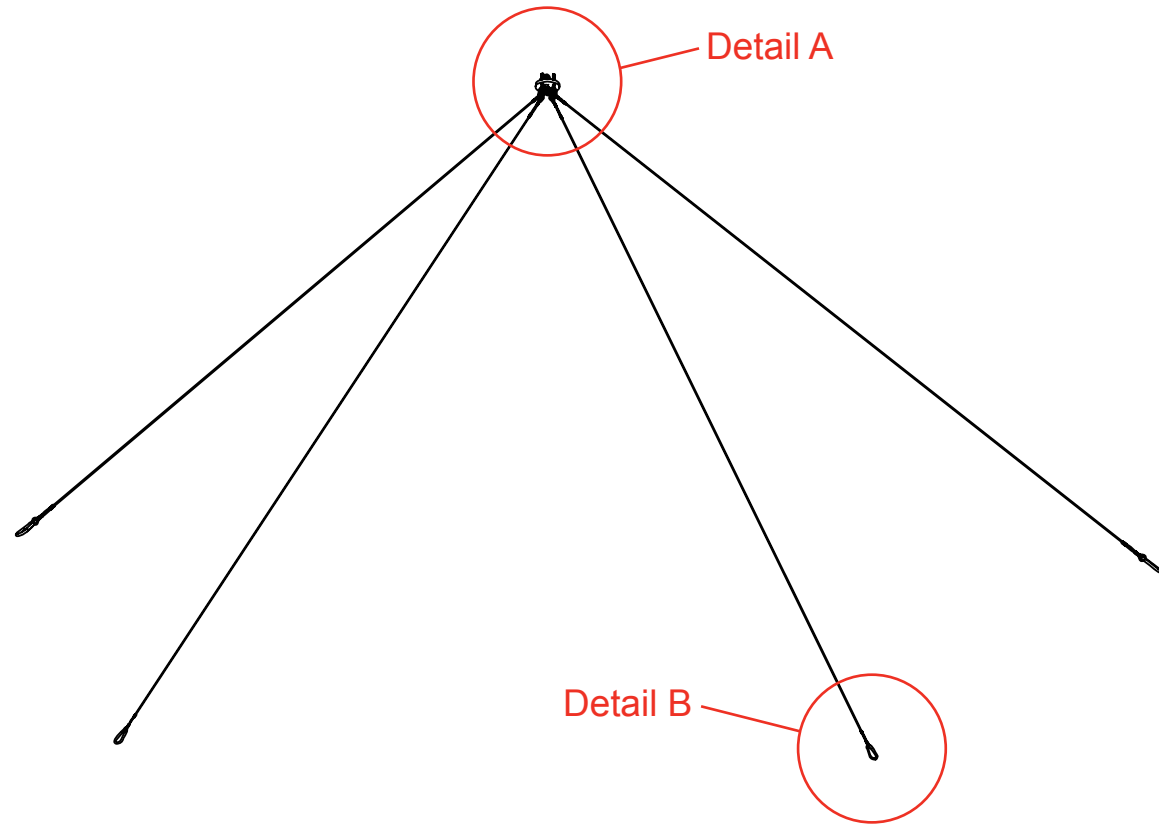

Construction consists of the following materials:

1. 302/304 (1/8") Stainless Steel Cable (Rated at 1760 lbs break strength)
2. Plated Spring-loaded Interlocking Snaps (Rated at 280 lbs working load)
3. Nicoperss Oval Sleeves (Holding strength rated at 900 lbs)
4. 0.25" x 4" Diameter T6061 Aluminum Plate
5. Eye Bolts (Rated 900 lbs on vertical lift and 450 lbs on 45 degree lift)

Harness Strength Calculation:

Hanging sign weight is calculated based on weight of the structure and the weight of the fabric:

1. The weight of the structure material is 0.29 lbs per linear feet
2. The weight of the fabric is 0.04 lbs per sq. feet

Based on information above, one string of the harness at a standard 90 degree sling angle will accommodate 163 sq. feet surface measured sign. The vertical string will hold 233 sq. feet surface measured sign.

